

DQ258M is 2-phase stepper motor driver based on advanced DSP control. It is new fully digital driver configured by DSP control chip and unique circuit. The driving voltage is DC24V-80V, adapting to all models of 2-phase hybrid stepper motor whose current is below 5.0A and with 42-57mm outer diameter. The internal driver circuit is similar to that of servo control, which makes the motor run smoothly, almost no vibration and noise. The max positioning accuracy can be 40,000 steps/R. It is widely applied in medium/small NC equipment with high resolution like engraving machines, small CNC machine, packaging machinery and etc.

Features

- High performance and competitive price
- 16-channel selectable resolution, max 40,000 steps/R
- Max response frequency up to 200Kpps
- Coil current will be automatically reduced to 1/2 of pre-set current when stepper pulse stops over 100ms.
- Optical isolating signals I/O
- Driving current can be adjusted from 1.2A/phase to 5.0A/phase through the 16 channels.
- Single power supply (Voltage range: DC24V-80V)
- Phase memory function (Note: The driver can memorize the motor phase automatically when the input stops over 3 seconds. And also it can recover the phase automatically when it is re-powered or MF signals changes from low level to high level.)

Current Setting

The working current of the driver is set by DIP-1 terminal. For more details, please refer to the following diagram.

Current (A)	1.2	1.5	2.0	2.3	2.5	3.0	3.2	3.6	4.0	4.5	5.0	5.0	5.0	5.0	5.0	5.0
D1	OFF	OFF	OFF	OFF	OFF	OFF	OFF	OFF	ON	ON	ON	ON	ON	ON	ON	ON
D2	OFF	OFF	OFF	OFF	ON	ON	ON	ON	OFF	OFF	OFF	OFF	ON	ON	ON	ON
D3	OFF	OFF	ON	ON	OFF	OFF	ON	ON	OFF	OFF	ON	ON	OFF	OFF	ON	ON
D4	OFF	ON	OFF	ON	OFF	ON	OFF	ON	OFF	ON	OFF	ON	OFF	ON	OFF	ON

Micro Steps Setting

The micro steps of the driver are set by DIP-2 terminal with total 16 channels. They are set separately by the first 4 of the 6 DIP-switch. (The other 2 are for function setting).

Details are as below. Micro steps (pulse/R)

	200	400	800	1000	1600	2000	3200	4000	5000	6400	8000	10000	12800	20000	25600	40000
D1	ON	ON	ON	ON	ON	ON	ON	ON	OFF	OFF	OFF	OFF	OFF	OFF	OFF	OFF
D2	ON	ON	ON	ON	OFF	OFF	OFF	OFF	ON	ON	ON	ON	OFF	OFF	OFF	OFF
D3	ON	ON	OFF	OFF	ON	ON	OFF	OFF	ON	ON	OFF	OFF	ON	ON	OFF	OFF
D4	ON	OFF	ON	OFF	ON	OFF	ON	OFF	ON	OFF	ON	OFF	ON	OFF	ON	OFF
D5	ON, double pulses: PU is CW stepper pulse signal, DR is CCW stepper pulse signal.															
	OFF, single pulse: PU is stepper pulse signal. DR is the direction control signal.															
D6	Self-test switch (OFF: receiving external pulse ON: the driver is running at 30 r/min internal)															

I/O Signals

All input signals are optically isolated. To guarantee the reliable running of the built-in high-speed optocoupler, the driving current to control the signal is required to be 15mA at least. And the driver has been set in the optocoupler resistance. When the input voltage is beyond 5V, please limit the current by connecting R if necessary.

Current-limiting Resistance value:

When controller/actuator signal outputs voltage:

+5V, R1=0, R2=0

+12V: R1=510Ω, R2=820Ω;

+24V: R1=1.2KΩ, R2=1.8KΩ

Common Anode Connection for Signal Input

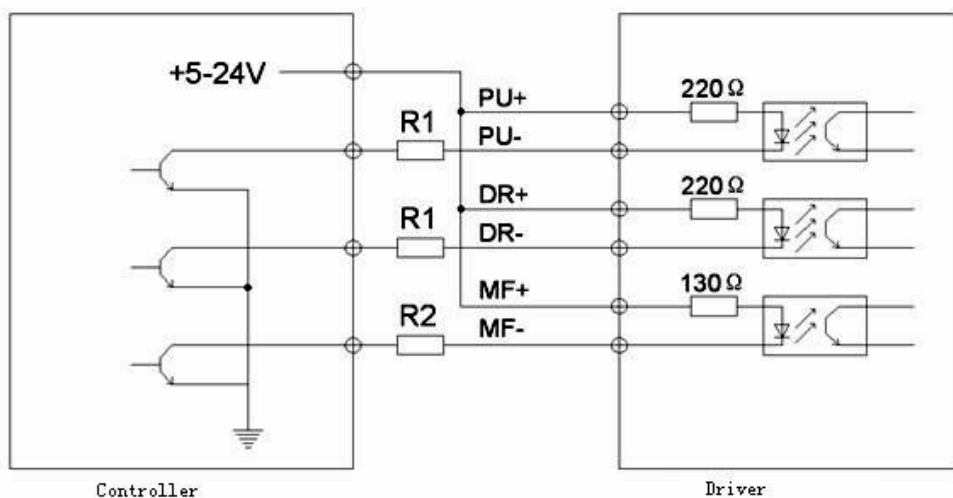

Common Cathode Connection for Signal Input

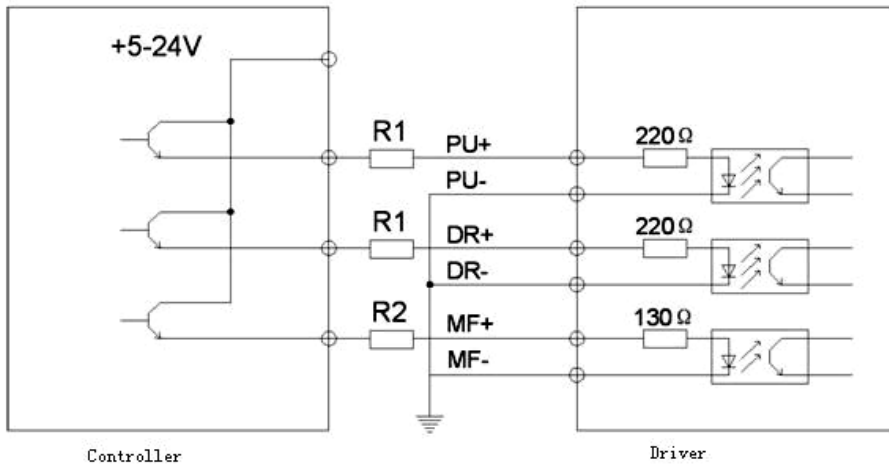

Connection for Differential Signal Input

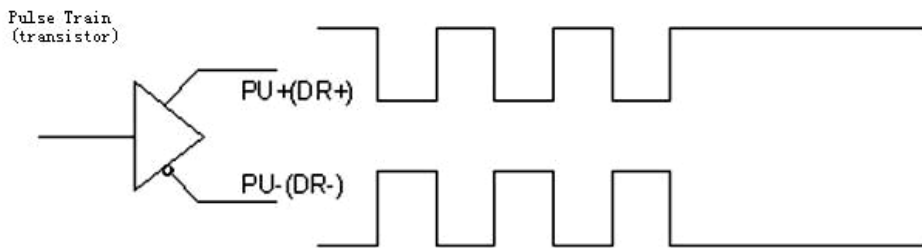

Signal Output

The driver outputs the signals through optocoupler. The max driving current can be 50mA.

RDY Signal Output

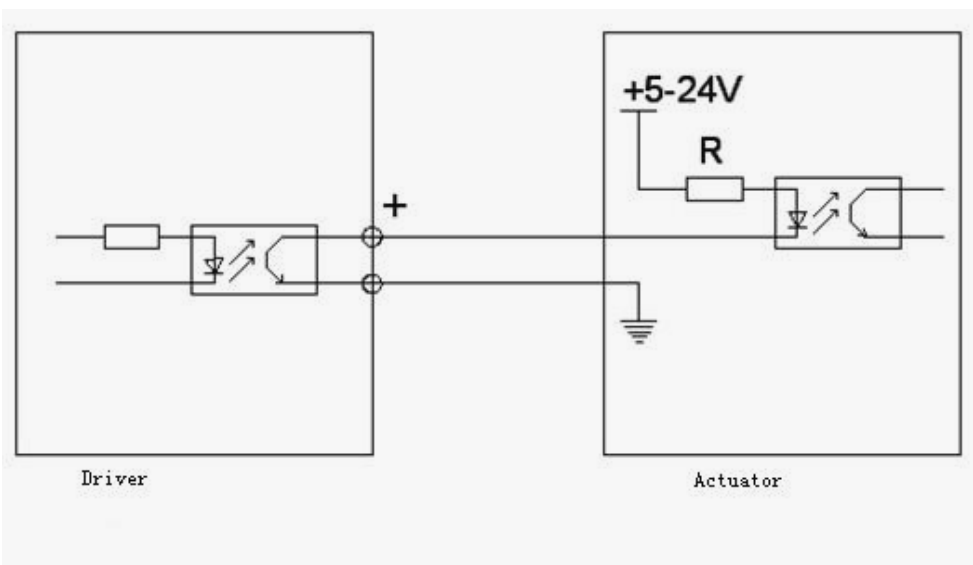

Waveform Diagram of Signal Input

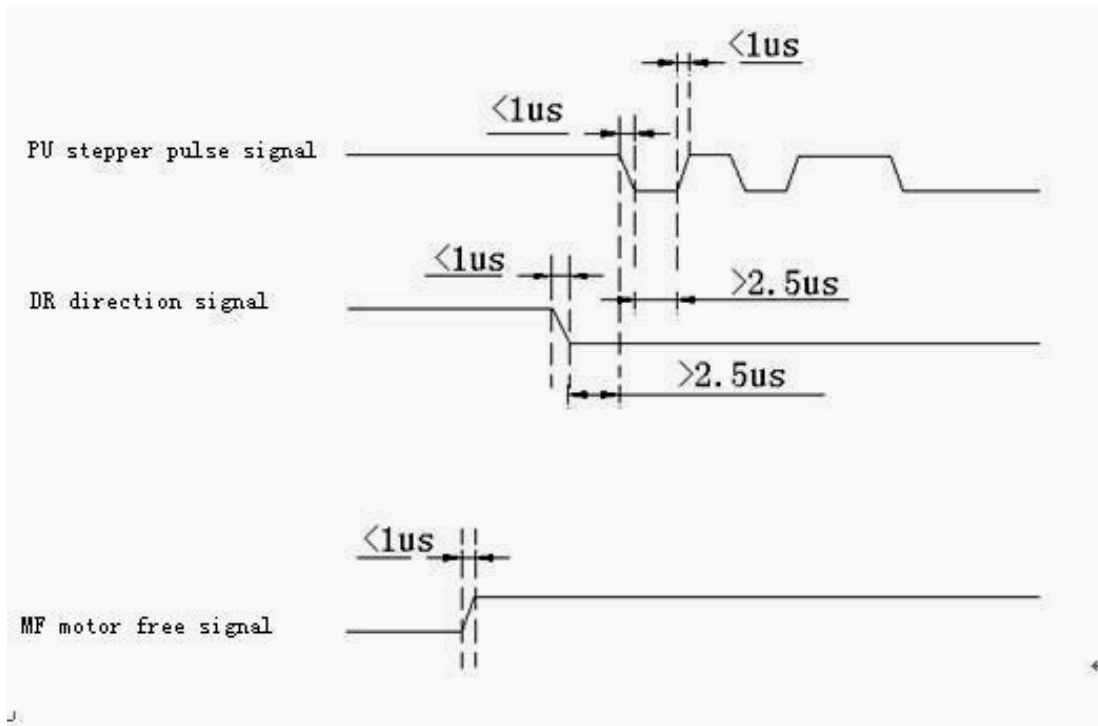

!Caution

- The input voltage can not exceed DC80V;
- The input control signal level is 5V. Once it is over 5V, please connect resistance to limit current.
- The input of pulse is valid on the trailing edge.
- The driver will stop working once the temperature exceeds 75 degrees. And the ALM will light. Until the temperature drops to 50 degrees, the driver will restart to work after powered-up. Please install the radiator for over-heat protection.
- If short circuit ALM lights, please check motor leads and eliminate other short faults. And then repower up.
- If no motor ALM lights, please check motor leads and repower up.

Diagram of Driver Wiring & Dimension (Unit: mm)

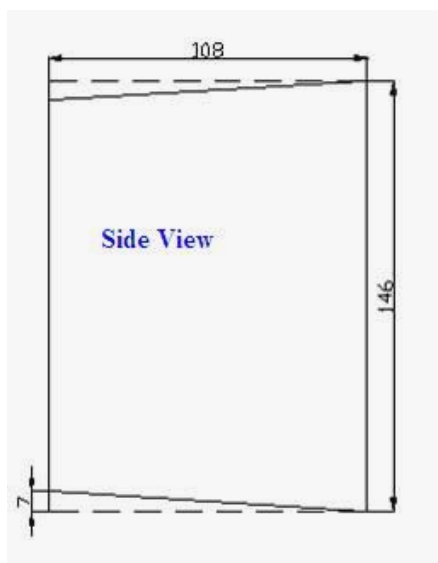
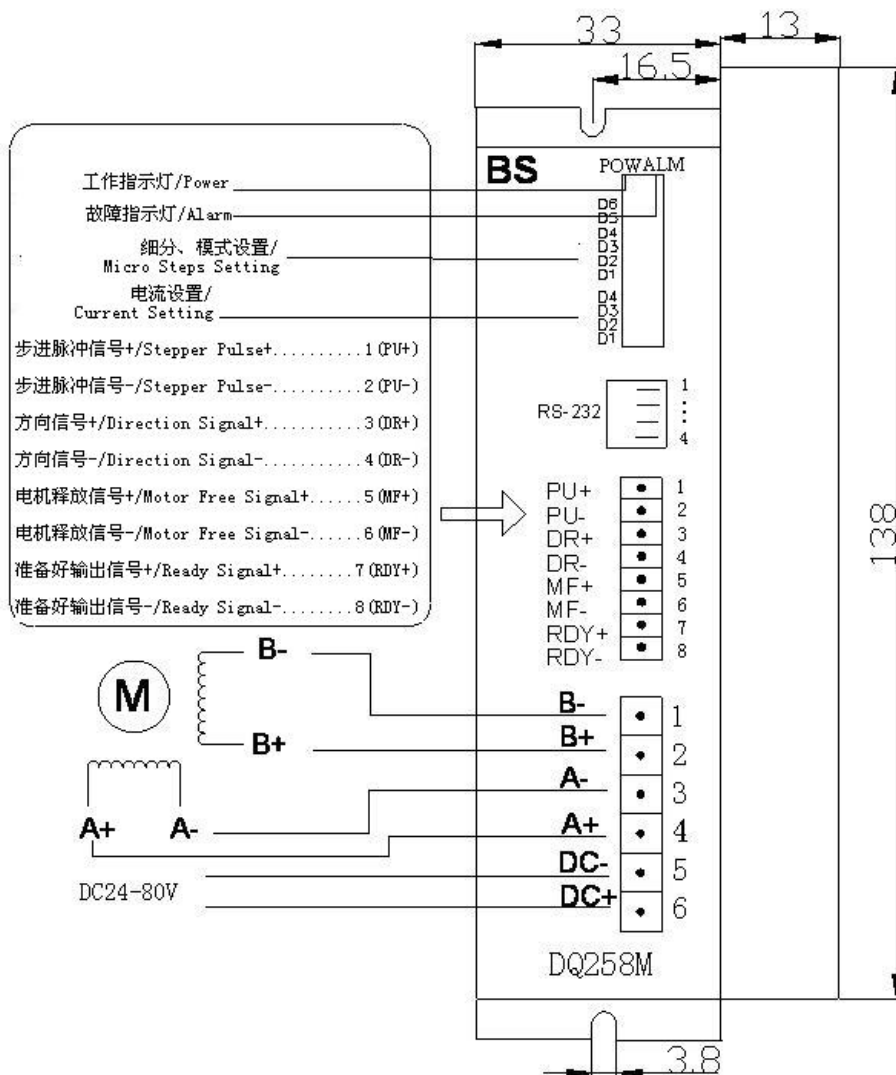

Lead Pin Function Table

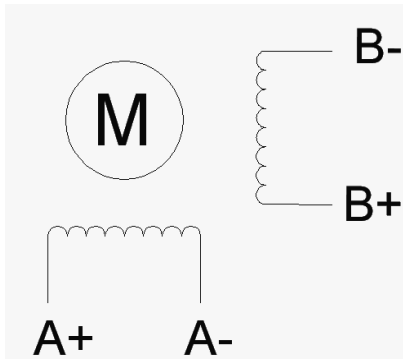
Port	Pin No.	Symbol	Function	Note
RS-232	1	RX	To receive data	NC
	2	TX	To send data	NC
	8	GND	Ground	NC
Signal Port	1	PU+	Input Pulse Signal +	Driving voltage+5V~+24V, but if above +5V, current limit resistance is needed.
	2	PU-	DP5= OFF, PU: stepper pulse signal	It is valid on the trailing edge. Each time pulse changes from high level to low level, motor rotates one step and inputs resistance 220Ω. Request: Low level 0-0.5V, high level 4-5V. Pulse width>2.5μS
			DP5=ON, PU: CW stepper pulse signal	
	3	DR+	Input direction signal +	Driving voltage+5V~+24V, but if above +5V, current limit resistance is needed.
	4	DR-	DP5=OFF, DR: direction control signal	To change motor rotating direction and input resistance 220Ω. Request: Low level 0-0.5V, high level 4-5V. Pulse width>2.5μS
			DP5=ON, DR: CCW stepper pulse signal	
	5	MF+	Input motor free signal +	Driving voltage+5V~+24V, but if above +5V, current limit resistance is needed.
	6	MF-	Motor free signal.-	Cut off motor current when it is valid (low level). The driver stops working and in free state.
7	RDY+	Output ready signal +	It is valid (low level) when driver works normally and ready to receive the signal from controller.	
8	RDY-	Output ready signal -		
Motor Power Port	1	DC+	Power supply	DC24~80V
	2	DC-		
	3	A+	Motor leads	 <p>The diagram shows a stepper motor symbol 'M' in a circle. Below it are two coils representing the motor leads. The left coil has terminals labeled 'A+' and 'A-'. The right coil has terminals labeled 'B+' and 'B-'.</p>
	4	A-		
	5	B+		
	6	B-		

Possible Problems & Solutions Table

Problems	Possible Cause	Solutions
Motor Stopped	Indicator does not light.	Check power supply
	ALM lights.	Check if the driver over-current, over-heat, or lack of motor.
	Motor spindle is locked.	Check external control signal.
	The indicator works normally, the spindle does not lock the motor.	Check if MF signal is valid.
Motor Stalled	The max speed is over-set.	Reduce the speed.
	Accelerating time is too short.	Lengthen the accelerating time or increase the constant value of pulse wave filtering.
Inaccurate Position	The Micro steps set incorrectly.	Choose correct micro steps.
	The motor load is too heavy.	Change the motor or appropriately increase driver running current.
Electric Leakage	Not reliably grounded.	Make the driver/motor reliably grounded.
Driver/Motor Over-heat	Heavy running current or terrible external heat sinking condition	Appropriately reduce running current or improve the ventilation and heat dissipation.